

**Thermo
Electric
Devices**

PRODUCT DATA SHEET

TDEX3132/100FMF12G

HIGH PERFORMANCE HEAT SINK / FAN ASSEMBLY

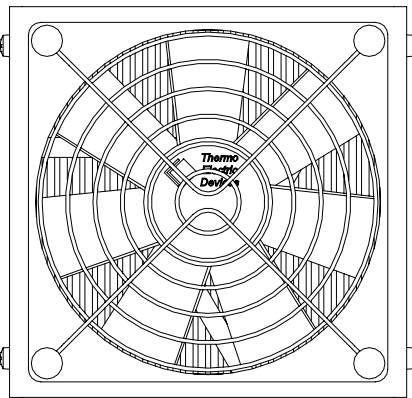
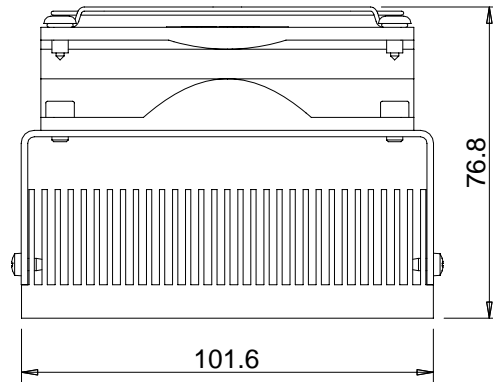
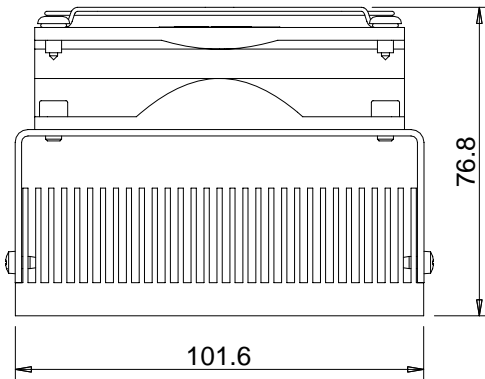

Applications

The TDEX3132/100FMF/12/G is a high-performance extruded fin aluminium heat sink / fan assembly designed for use with single thermoelectric (Peltier effect) coolers of up to 40mm x 40mm footprint and up to 80W Qmax.

It would be equally suitable for other semiconductor applications requiring high performance within a compact footprint.

- L: 100 W: 101.6 D: 77mm Mass: 650g
- 6035-T5 Aluminium
- Anodized finish
- 92mm 12V (2.0W) fan
- Machined thermal interface = excellent thermal transfer
- 8mm thick sole plate for good thermal conductivity
- Thermal resistance 0.16 deg C/Watt
- Finger guard included

Thermo Electric Devices
Unit 1 Draycott Business
Centre
Draycott
GL56 9JY
UK

T: 01386 701703
F: 01386 701618
E: mail@thermoelectricdevices.co.uk
W: www.thermoelectricdevices.co.uk