

SOLID STATE DIGITAL METER MODULES

700 SERIES

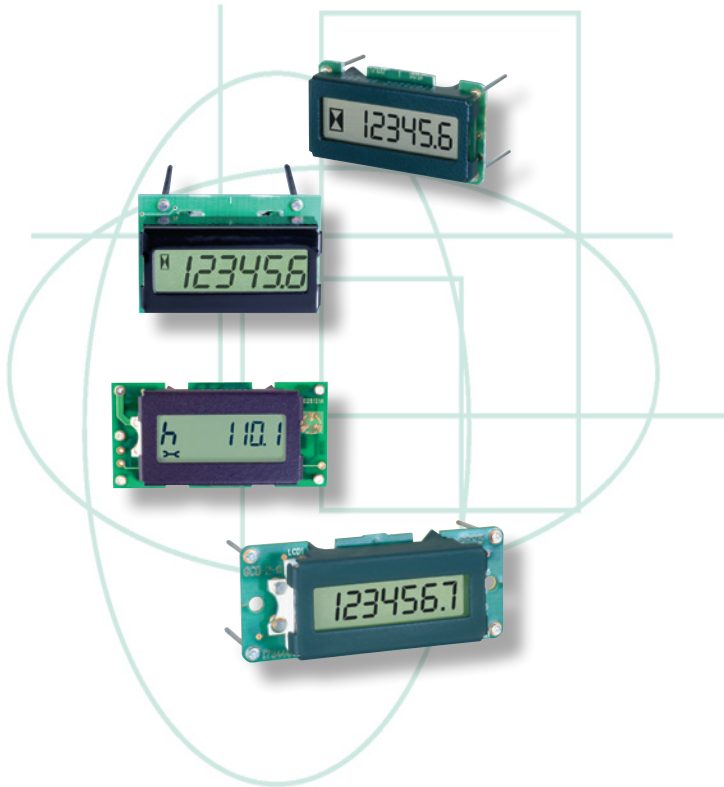

CURTIS



DESCRIPTION

Curtis Solid-State Module Assemblies are designed for OEM applications. Curtis offers a wide selection of miniature AC & DC meter assembly modules for PC board mounting applications.

700 – 703: Single-function 6-digit display for Counter or Hour Meter configurations.

708 & 721: Dual channel, 6 & 7 digit display for Maintenance/ Hour Meter or Trip Odometer configurations.

720: Single channel 7-digit Odometer configuration.

APPLICATIONS

These models offer a variety of functions, sizes, voltages and customizable options to fit most applications. Ideal for OEMs, contract manufacturers, and panel makers for monitoring equipment usage, scheduling maintenance, warranty validation, rental/leasing use and more. Used extensively in industrial, agricultural, military & specialty vehicles, as well as applications such as: vending machines, medical & office equipment, fuel pumps, and consumer products.

FEATURES

- Selection – hour meters, counters, odometers, maintenance monitors and more.
- Solid State Circuitry – no moving parts to wear out. Silent operation and years of rugged & reliable operation.
- Crisp, clean readouts – high-contrast 5 & 7mm LCD displays.
- Versatility – compact module designs with high quality components to minimize space.
- AC/DC Configurations – wide range of operating voltages & noise protection.
- OEM Compatibility – an unparalleled selection of power compatibility, design configurations and functionality for OEM custom designs, panel makers and contract manufacturers.
- Distinctive Icons – clear indicators for hour meter/timer activation and display modes.
- Backlighting – available on all models (see model coding chart or consult factory).
- EEPROM memory – nonvolatile, retention of data for as much as 25 yrs.+ without power.
- Manufactured under ISO 9001 Certified Quality Management System.
- Low power consumption.
- UL and CE recognized.

700 SERIES

MODEL CODING ASSEMBLY MODULES 700, 701, 703

700	P	N	- 0	0	0
Model Number	Digit Height	Reset Control Options	Functions	Voltage	Reset/Backlight Configurations (1)
700 (6-digit) Hour Meter	P - 5mm digits	R - Wired Reset N - No Reset	0 - AC/DC (700 only)	0 - 5-12 VDC nom (4.75-15 abs) 6-12 VAC nom (5-15 abs)	0 - No Reset, No Backlight 2 - Reset, No Backlight
701 (6-digit) Hour Meter	P7 (2) - 7mm digits		1 - DC only with wired Enable for Hour/Count (701&703 only)	1 - 12-48 VDC nom (9-60 abs) 20-60 VAC nom (15-75 abs)	4 - Reset, External Backlight 5 - No Reset, External Backlight
703 (6-digit) Pulse Counter			2 - AC/DC with wired Enable (701&703 only)	2 - 48-150 VDC nom (36-185 abs) 100-230 VAC nom (75-287 abs)	H - Reset, Internal Backlight (3) J - No Reset, Internal Backlight (3)
				4 - 12 VDC only (9-15 abs) Backlight Options 4 & 5 only.	

NOTE: (1) All external backlight configurations - require 12 VDC (only) connection to illumination pin.
 (2) 7mm models - Backlighting only available as External.
 (3) Available only in 5mm & with voltage option 4 only.

MODEL CODING ASSEMBLY MODULES 708, 720, 721

708	P	R	- x x x x
Model Number (& Function)	Digit Height	Reset Control Options	Sequential Specification
708 (6-digit) Dual Channel Maintenance/Hour Meter	All Models P - 5mm digits	Model 708/721 R - Wired Reset for Maintenance or Trip Display	Consult Curtis for: display format, voltages, connection termination, backlighting, pre-scaling and programming options.
720 (7-digit) Single Channel Odometer		Model 720 R - Wired Reset	
721 (7-digit) Dual Channel Odometer/Trip Odometer			

700 SERIES

MODULE ASSEMBLY SPECIFICATIONS

Display	6-digit, 5 or 7 mm high	(Models 700, 701, 703)
	Dual-Channel 6-digit, 5 mm high	(Model 708)
	7-digit, 5 mm high	(Model 720)
	Dual-Channel 7-digit, 5 mm high	(Model 721)
Range & Resolution	Hour Meters 99,999.9 hrs.	(Models 700, 701, 708)
	Maintenance 3,999.9 hrs.	(Model 708/2nd Channel)
	Counters 999,999 counts	(Model 703)
	Odometers 999,999.9 increments	(Models 720, 721)
	9,999,999	(Model 720) optional resolution
Trip 999.9	(Model 721/2nd Channel)	
Accuracy	Hour Meters $\pm 0.1\%$	(Models 700, 701, 708)
	Counters ± 1 count	(Model 703)
	Odometers ± 1 increment	(Model 720, 721)
Humidity	95% Non-condensing at 38°C	
Operating Temperature	-40°C to + 85°C	
Storage Temperature	-50°C to + 85°C	
Operating Frequency (AC units)	48 to 440 Hz abs.	
Memory	Main power must be applied for 5 sec to activate memory (with no loss of time/counts). EEPROM-Data retention 25+ years without power present.	
Input Signal (DC Only)	Counter	Model 703 - 500 Hz max, 50% duty cycle (1ms low, min, between consecutive highs).
	Maintenance Monitor	Models 701, 708 - Power must be applied for 0.5 sec, min, to accumulate time.
	Odometer	Model 720 - Varies depending on model configuration (consult factory).
	Trip/Odometer	Model 721 - 500 Hz max, 50% duty cycle (1ms low, min, between consecutive highs).
Input Signal (AC/DC)	Hour Meter	Models 701, 708 - Power must be applied for 0.5 sec, min, to accumulate time.
	Counter	Model 703 - 1 Hz max, 50% duty cycle (500ms low, min, between consecutive highs).
Reset	All Models	Main power must be applied for a minimum of 0.5 sec. prior to reset signal.
	Models 700, 701, 703	6ms, min, at operating voltage.
	Model 708	Maintenance 2 or 4 sec, factory programmed; hour meter not resettable.
	Model 720	70ms min at operating voltage.
	Model 721	Trip channel 2 or 4 sec, factory programmed; odometer is not resettable.
		Note: Max Reset frequency is 150Hz for AC models.
Notes:	<ol style="list-style-type: none"> 1. All modules are supplied with critical components exposed. If the module is being used in an environment other than specified, the user must take precautions to package the module to provide adequate protection. 2. For proper mechanical support, all module pins should be soldered to the PC-board. 3. To prevent heat damage to components, module face should be 10-20mm minimum away from PC-board when flow soldered. 	

700 SERIES

CURRENT CONSUMPTION: (MA MAX)

	Operating Voltage at Power Terminals	700, 701, 703	700, 701, 703	708, 721	
		(5mm)	(7mm)	(5mm)	
External or Non - Backlight Models	5 - 12	VDC (@ 5 V)	0.5	0.5	N/A
	12 - 48	VDC (@ 12 V)	0.8	0.8	1.0
	48 - 150	VDC (@ 48 V)	0.8	0.8	N/A
	100 - 230	VAC (@ 120 V)	1.0	1.0	N/A
	100 - 230	VAC (@ 230 V)	2.0	2.0	N/A
Internal Backlight Models	12	VDC (only)	35	N/A	N/A
At Illumination Pin					
External Backlight Models	9-15 VDC (@12 V)	30	35	35	

DIMENSIONS mm

MODELS 700, 701, 703 - 5MM DIGITS



Non-Backlight

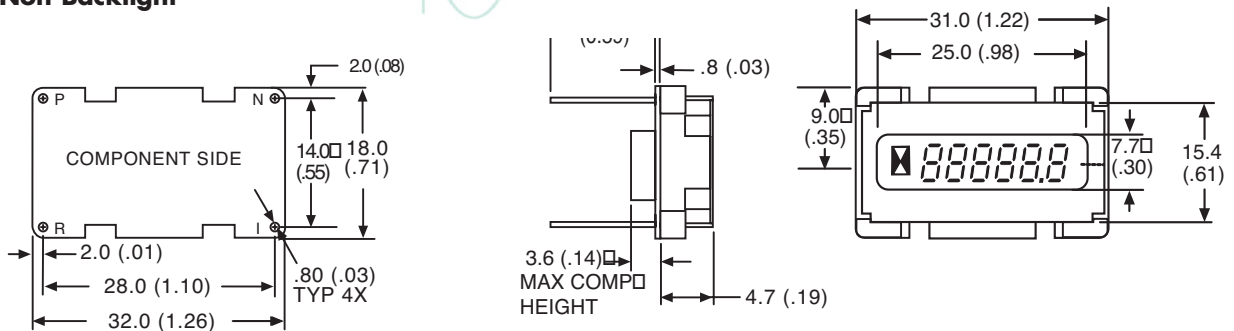

Backlight

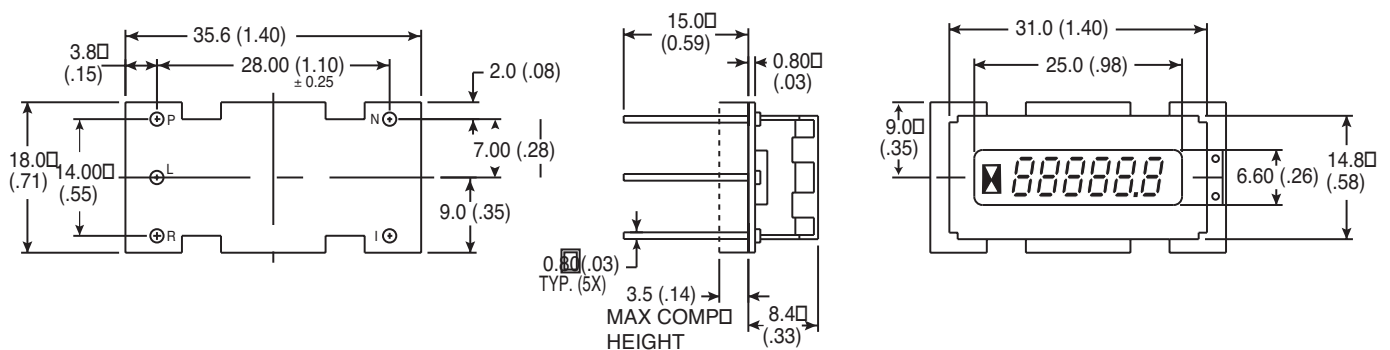

Note: Standard pin lengths are shown. Optional lengths are available.

700 SERIES

DIMENSIONS mm continued

MODELS 700, 701, 703 - 7MM DIGITS

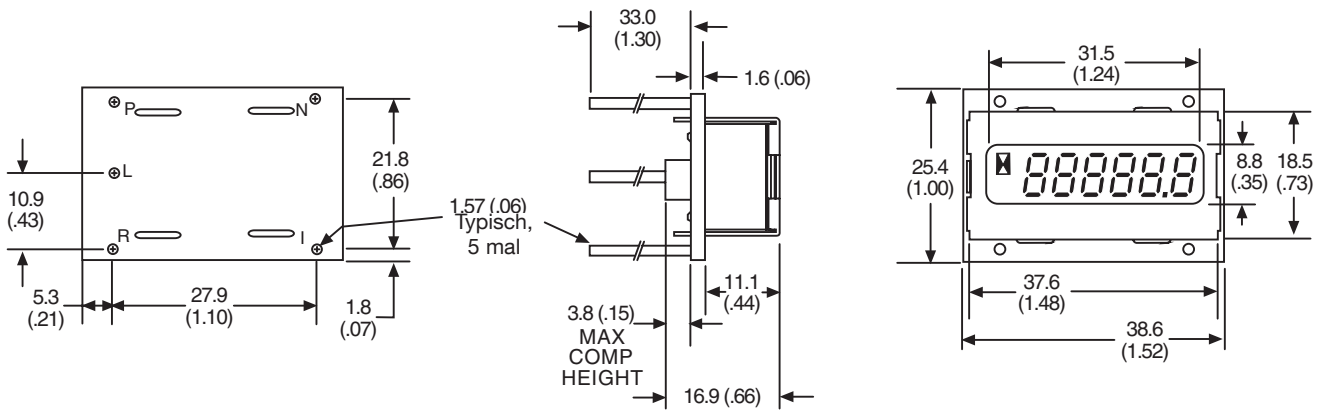

Model 708



Model 721

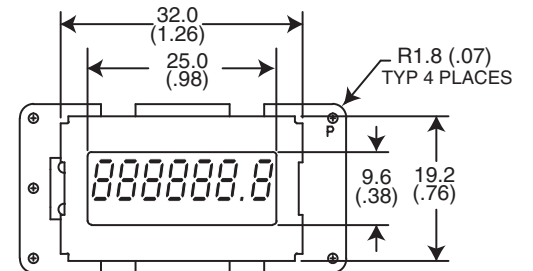
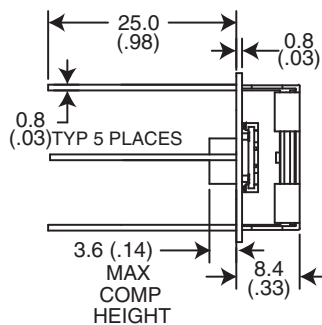
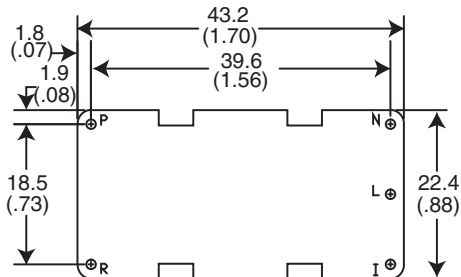

Note: Standard pin lengths are shown. Optional lengths are available.

700 SERIES

DIMENSIONS mm continued

MODEL 720

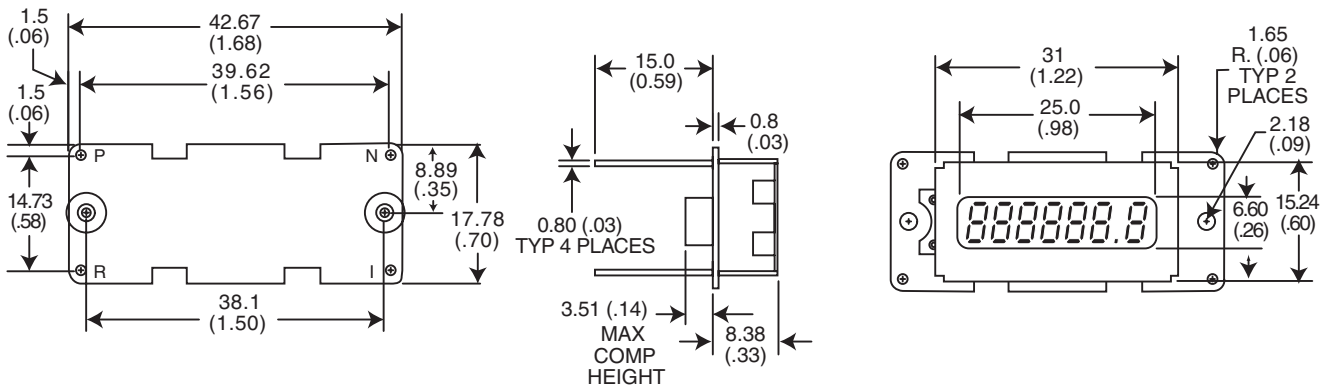
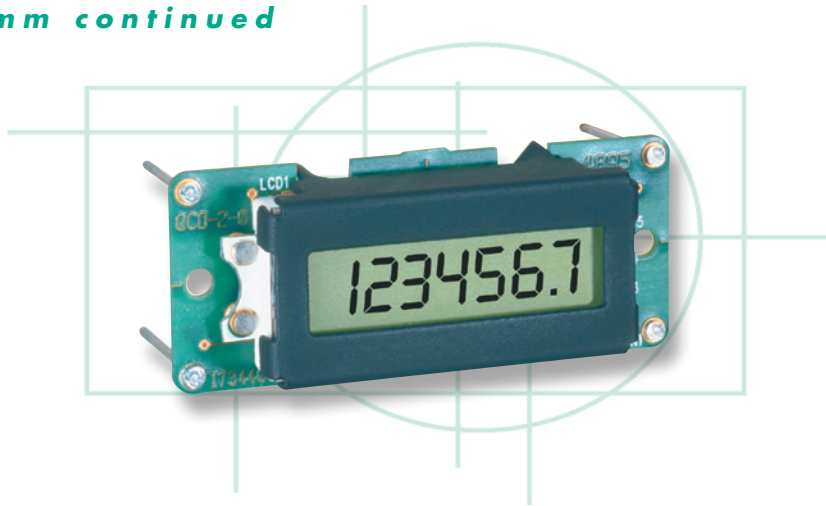

Note: Standard pin lengths are shown. Optional lengths are available.

MODULE WIRING GUIDE

Pin IDs	Assignment
P	V+
N	V- (common)
I	Enable V+ to activate elapsed time (Optional on 701, 708, N/A on 700) or increment count (703, 720, 721).
R	Reset V+ to reset count/elapsed time to zero (720, Optional on 700, 701, 703) or resettable channel to zero (Models 708, 721).
L	Illumination Control - 12 VDC only (Optional, external backlight units only) 9-15 VDC absolute, regardless of operating voltage.

WARRANTY Two year limited warranty (see terms of sale for specifics).

